

NOTE:  
ALL DIMENSIONS ARE IN INCHES.

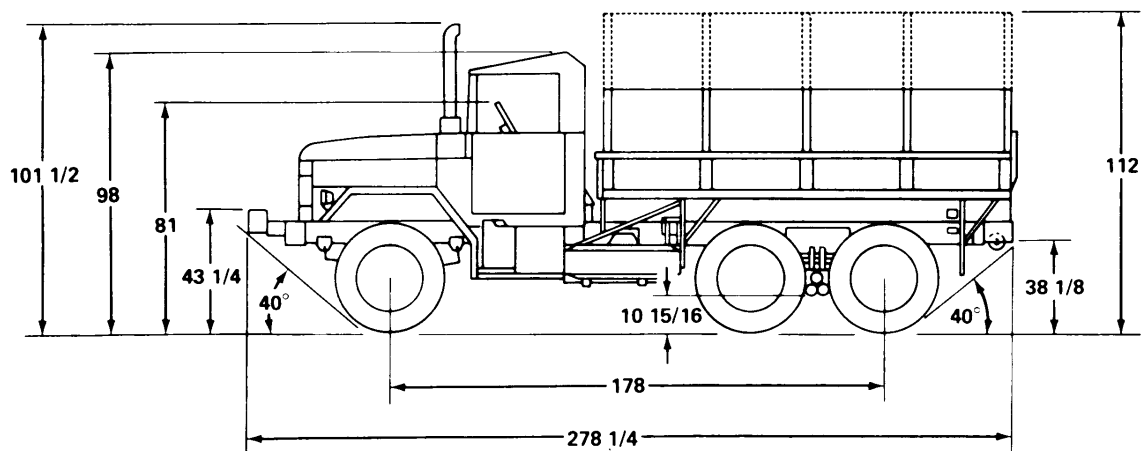
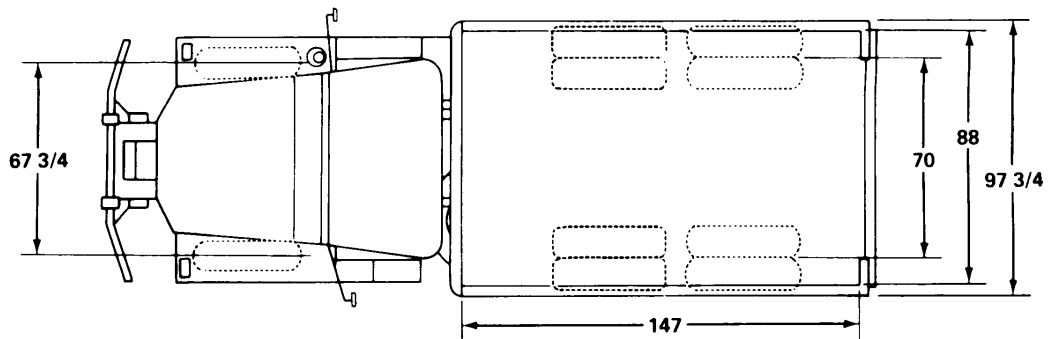

TA208699

**PURPOSE:** This vehicle is employed by various support units primarily for cargo or personnel. It is especially well-suited for forklift cargo handling.

#### GENERAL INFORMATION

Nomenclature: TRUCK, CARGO: 2 1/2 Ton,  
6x6, Drop Side, W/Winch

Model Number: M35A2C

Crew/Cab Capacity: 2

NSN: 2320-00-926-0875

LIN: X40214

SSN: D131030

TM: 9-2320-209-Series

#### CHARACTERISTICS

Engine: Multifuel

Horsepower: 140 bhp @ 2,600 rpm

Transmission: Manual; 5 Fwd, 1 Rev

Electrical System: 24 Volt

Tires: 9:00 x 20, 8-ply

Brakes: Air over hydraulic

Blackout Lights: Yes

#### PERFORMANCE DATA

Fording:

W/Kit: 72 in

WO/Kit: 30 in

Approach Angle: 40 Degrees

Maximum Speed: 58 mph

Range: 350 miles

#### VEHICLE DATA

Type Classification & Date: Std A, 1970

Replaces: None

Life Expectancy: 15 Years

Payload: 10,000 lb, Off Road: 7,000 lb

Towed Load Allowance: 6,000 lb

Air Transportability: Phase II

#### EQUIPMENT OPTIONS

Kits: Personnel Heater, Winterization,  
Fording, Electric or Air Brakes,  
Troop Seat, Cargo Body Closure (Arctic),  
"A" Frame

Winch: Yes

#### SHIPPING DATA

Weight: 13,700 lb

Cube: 1,252 cu ft

Ground Clearance: 10 15/16 in